

03 Product Specification

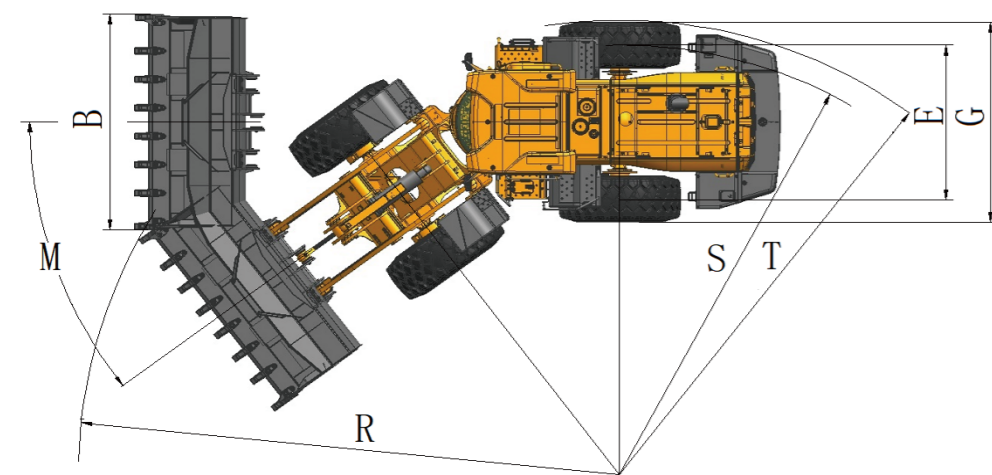

A	Overall Length, mm	8910	K	Maximum Lifting Height, mm	6110
B	Overall Width, mm	3100	L	Angle of Departure, °	29
C	Overall Height, mm	3520	M	Steering Angle, °	38
D	Wheelbase, mm	3500	P	Angle of Discharge, °	44
E	Track Width, mm	2300	Q	Transport Angle, °	44
G	Main Unit Width, mm	3000	R	Turning Radius (Outer Side of Bucket), mm	7360±50
H	Dumping Height, mm	3340	S	Turning Radius (Center of Tire), mm	6220±50
I	Dumping Distance, mm	1200	T	Outer Tire Turning Radius, mm	6590±50
J	Maximum Hitch Height, mm	4480	V	Min. Ground Clearance, mm	510

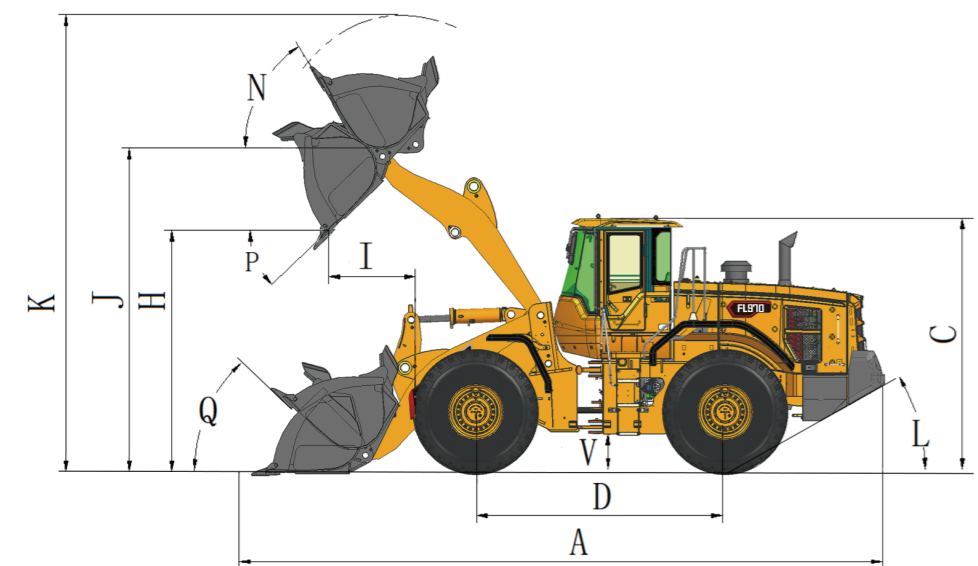

WE AIM AT CUSTOMERS' SATISFACTION

Lovol Heavy Industry, a wholly state-owned subsidiary under Weichai Holding Group, was established in 2004. It currently possesses "three manufacturing bases and two innovation centers".

Lovol Heavy Industry's business is one of the six core business segments of Weichai Group. Its products cover four main categories including excavators, loaders, off-highway mining trucks, and backhoe loaders. The R&D, production, and sales center of excavators, loaders, and backhoe loaders is located in Qingdao, covering an area of over 900 acres. The R&D and production center of off-highway mining trucks is located in Yangzhou, Jiangsu, covering an area of over 300 acres. Lovol Heavy Industry has gradually developed into a global leader in intelligent construction solutions by providing customers with intelligent products, equipment interconnection, intelligent construction, new energy products, and scenario solutions.



Official Website



Facebook

LOVOL HEAVY INDUSTRY GROUP CO.,LTD.

Address: No.75, Huanghe East Road, Huangdao District, Qingdao City, Shandong Province, China.

Website: en.wlovol.com

Z20250325-6

Information of Lovol Heavy Industry Agents

© As manufacturer, LOVOL has right to constantly upgrade and improve our products without informing to customers.
 © The pictures in literatures are for reference only, the detailed specifications are subject to real products.

LOVOL



Engine Model:
WEICHAI WP10HG260E670

Rated Power:
192kW/2100rpm

Total Machine Weight:
22100kg

Standard Bucket Capacity:
4.0m³

FL970

LOADER

Technical specifications and designs are subject to change without notice and additional equipment may be installed on the supplied machines.

01 Product Introduction

LOVOL

Core Configuration WEICHAI WP10H Euro Stage V engine + ZF fully automatic electronically controlled transmission + wet swing axle with limited-slip differential + combined variable and constant displacement hydraulic system.

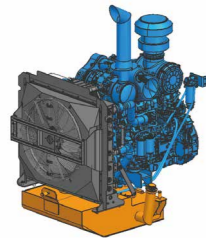

WEICHAI WP10H Euro V Engine

192kW

Customize and develop an exclusive performance curve and a dedicated fuel map, enabling a more perfect coordination between the engine and the transmission system. This can enhance economy and responsiveness, and reduce fuel consumption.

Hydraulic independent cooling system capable of backflushing.



ZF BP230 Transmission

Fully automatic shifting with proportional solenoids and electronic control systems for higher efficiency.

Pilot single-lever operation with an FNR button for easy handling.

Wet drive axle with limited-slip differential, equipped with a full hydraulic dual braking system, offers good adaptability and reliable braking.

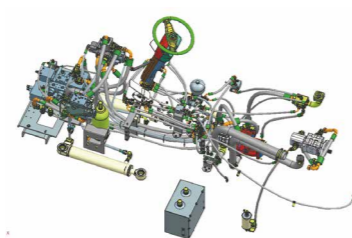

The fixed-variable dual-pump confluence hydraulic system patented by Lovol

Fuel-efficient and capable of compound actions; the steering gear is elastically connected to the steering column and the cab, resulting in lower noise.

Adding an arm shock absorber valve enhances stability and comfort on bumpy roads.

Reinforced Machine Body, Efficient And Reliable.

Front and Rear Frame

- The front and rear axle track is centrally arranged with a long wheelbase; the front axle features a wide opening structure, making it more suitable for heavy loads.
- Lovol patented hybrid articulated structure, with high load-carrying capacity and reliability.
- After CAE structural and strength analysis, and validated through millions of cycles of impact fatigue testing, ensuring high reliability.
- The K-series counterweight structure, with rear combination lights integrated into the counterweight, is more aesthetically pleasing and safer.



02 Product Introduction

WE AIM AT CUSTOMERS' SATISFACTION

Lovol K-series cab



Interior

The front cab glass uses dual-curvature large opening safety glass, and the rear window features a large opening design, significantly enhancing the driver's forward and rearward visibility needs; Standard air-suspension seat with heating, dual-track adjustment, and a 135° reclining angle to improve driving comfort; the cab is certified with rollover protection (ROPS) and falling object protection (FOPS); Standard features include air conditioning with heating and cooling, rearview monitoring, trip computer, and emergency engine shutdown.

Appearance

Brand new protective cover design, with a full and imposing appearance; Triple door design, with the addition of a fully enclosed rear mudguard to reduce mud splashing during travel, enhancing safety and highlighting the aesthetic appeal of the exterior; The side doors of the cover and the rear window feature a large opening, upward-lifting design, improving the machine's maintainability.

Working Device

- The main articulation points of the working equipment and the swinging frame of the rear axle are equipped with 20GrMnTi honeycomb self-lubricating bushings, resulting in a longer service life and longer maintenance intervals.
- Bucket wall plates, main and auxiliary cutting edges, wear-resistant bucket bottom plates, and side plate linings are made of standard wear-resistant quenched materials, along with heavy-duty bucket teeth, significantly improving wear resistance and extending service life.
- The guide plates on the bucket protect the front glass of the cab and various pivot points during unloading.

03 Product Specification

FL970

Overall Machine Parameters

Rated Load Capacity, kg	6500
Operating Weight, kg	22100
Max. Traction Force, kN	170
Max. Digging Force, kN	180
Standard Bucket Capacity, m ³	4.0

Engine

Model	WEICHAI WP10HG260E670
Emission Class	Euro V
Engine Suction	Supercharge
Number of Cylinder-Bore	6-115×150
Displacement, L	9.5
Rated Power, kW	192
Rated Speed, rpm	2100
Max. Torque, N·m	1260

Gearbox

Transmission Brand	ZF BP230
Type of Transmission	Electro-controlled shifting with a countershaft transmission
Type of Torque Converter	Single-stage single-phase three-component
Torque Multiplication Factor	2.28
Number of Gears	4 forward, 3 reverse
Max. Speed, km/h	41.1

Axle

Type	Wet rear swing axle
Front and Rear Axle Reduction Type	Single-stage reduction with spiral bevel gears Wheel-side planetary gear reduction with straight cylindrical gears

Air Conditioning

Working Medium (warm/cold)	Coolant/R134a
Cooling Capacity, kW	4.5

Tires

Tire Specifications	26.5R25/L-3
Tire Rating	★★
Front Tire Pressure, Mpa	0.6-0.65
Rear Tire Pressure, Mpa	0.55-0.6

Working Hydraulics

Control Mode	Pilot control with compound actions
Working Hydraulic System Type	Combined system with variable and constant displacement pumps
System Operating Pressure, Mpa	23
Working Pump Model	CBGj2100SR02
Displacement, ml/r	100
Multi-way Valve Model	D32
Pilot Working Pressure, Mpa	4
Boom Lifting Time, s	5.7
Total Time for Three Operations, s	10.3

Braking

Service Braking	Full hydraulic wet brake
Parking Braking	Electronic control hydraulic braking
Brake Pressure, Mpa	8.27

Vehicle Body

Overall Dimensions of The Cab (Length × Width × Height), mm	1810×2030×1970
---	----------------

Oil

Fuel Tank (geometric volume), L	360
Hydraulic Oil Tank (level gauge midline), L	175
Engine Oil, L	21
Transmission Oil, L	27
Front and Rear Axle, L	34 forward/32 reverse
Brake pump, L	4
Antifreeze, L	56

