

TECHNICAL SPECIFICATIONS



Engine

| | |
|---------------------|----------------|
| Engine Model | YANMAR 4TNV98 |
| Number of Cylinders | 4 |
| Max. Torque/Speed | 237N·m/1400rpm |
| Displacement | 3.32L |



Hydraulic system

| | |
|----------------------------|----------|
| Max. Main Pump Flow | 139L/min |
| Main Safety Valve Pressure | 28MPa |



Main Performance

| | |
|----------------------|-----------|
| Bucket Digging Force | 56kN |
| Arm Digging Force | 38kN |
| Max. Traction Force | 61kN |
| Max. Walking Speed | 4.3km/h |
| Min. Walking Speed | 2.7km/h |
| Rotary Speed | 11.5r/min |
| Gradeability | 35° |
| Ground Pressure | 35.1kPa |



Oil Capacity

| | |
|----------------|--------|
| Fuel Tank | 160L |
| Hydraulic Tank | 100L |
| Engine Oil | 5-9.4L |



LOVOL CONSTRUCTION MACHINERY GROUP CO., LTD.

Address: No. 75, Huanghe East Road, Huangdao District, Qingdao City, Shandong Province, China.

Website: en.lovol.com

Alibaba: lovolconstruction.en.alibaba.com

Facebook: Cons Lovol

E-mail: lovol_overseas@global.lovol.com

TEL: +86-532-86907190

As manufacturer, LOVOL has right to constantly upgrade and improve our products without informing to customers. The pictures in literatures are for reference only, the detailed specifications are subject to real products.



Rated Power

44.4kW/2100rpm

Operating Weight

7800kg

Bucket Capacity

0.3m³

FR80E₂
EXCAVATOR



ENERGY-SAVING

LOVOL Customized Engine

Equipped with original YANMAR engine which is imported from Japan, the fuel injection system is perfectly matched with electric control system, it provides optimal fuel utilization to machine. The advanced fuel filter, oil filter and air filter can provide great protection to engine.

Efficient Hydraulic System

Hydraulic system adopts load-sensing hydraulic control system which is optimized by LOVOL Japan Engineering Center, it has excellent controllability and can adapts various applications.

Advanced Technology and Optimal Machine Performance

Adopts electronic- control main pump which can intelligently adjust the power matching between the main pump and the engine according to the loading changes, the fuel is dramatically saved while assuring high efficiency.



RELIABILITY

Superb Match

The key parts of the power system, hydraulic system and electronic control system are specially customized to achieve perfect matching and compatibility with one another, which deliver maximum reliability and longer service life.

Core Components

Relying on the R&D system of LOVOL Japan Engineering Center, LOVOL has established a solid partnership with world-renowned companies to continuously optimize and improve the quality and service life of our key components. Industry leading components are used on our machines including engine, pump, valve, motor, oil cylinder, controller and forth.

Reinforced Working Device

The front & rear support of boom and front support of arm are made of cast steel, which effectively reduces concentration of stress and increases the service life dramatically. The arm is also reinforced to improve the durability.

COMFORT

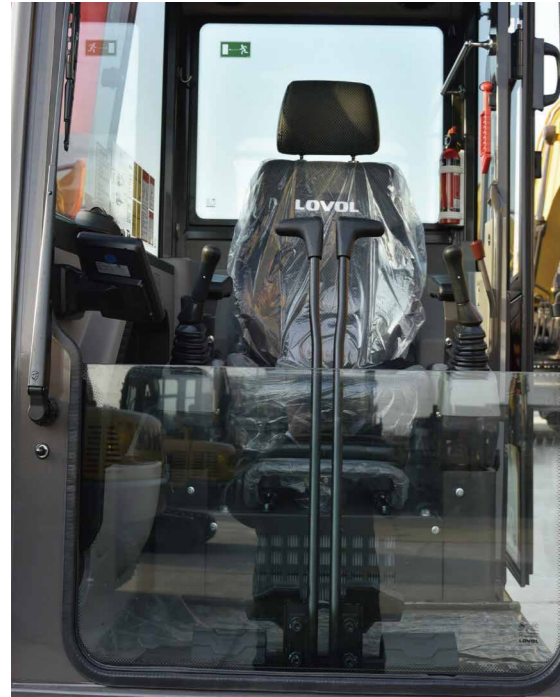

Large Spacious Cab

Equipped with spacious cab which provides operator large space to operate machine. The premium suspension seat with armrests is very comfortable and it can reduce the working fatigue dramatically. Big LCD screen is easy to read all data and to operate when working. Air conditioning is added for maximum comfort.

Ergonomic Design

The proportional joystick delivers sensitivity, accuracy and smoothness during operation. This joystick is specially designed to meet different operating conditions. Intelligent control system is standard which could control diverse attachments such as bucket, hammer, scarifier and hydraulic scissors.

Low Noise and Low Vibration

In order to reduce work fatigue and improve productivity, the noise inside of cab has been controlled to the lowest level. The cab is attached to the frame with buffer that dampens vibrations and sound levels to enhance operator comfort.

SERVICEABILITY



Engine hood and panels

The large engine hood increases maintenance space for operator to check and maintain the engine. The tool box is big with big opening angle which can put grease bucket and special tools easily. One key can open all locks of machine, it is very convenient for operator.

Electric and hydraulic parts

Pressure sensor is used on the main pump which can monitor hydraulic system's pressure when working. Centralized lubrication makes convenient and easy maintenance to slewing bearing, and the radiator is optimized for easy cleaning. These configurations make routine maintenance easy and convenient.

Filters and maintenance period

All the filters are fixed at ground level, it is very convenient to do routine maintenance. The maintenance interval is also extended to save time and cost.

INCREASE YOUR PRODUCTIVITY AND PROFIT WITH LOVOL ATTACHMENTS

You can easily expand the performance of your machine by utilizing any of the variety of LOVOL Attachments. Each LOVOL Attachments is designed to fit the weight and horsepower of LOVOL Excavator for improved performance, safety, and stability.



Log Grapple



Trenching Bucket



Hydraulic Rammer



Quick Coupler



Hydraulic Hammer



Standard Bucket



STANDARD CONFIGURATION

Engine

- 4-stroke water-cooled direct injection
- Radiator with protective fence
- Air Pre-filter
- Air intake heater
- Fan guard

Hydraulic System

- Automatic hydraulic system (flow confluence system)
- Multistage filtration system
- Cylinder buffer device
- Auxiliary hydraulic valve
- Dual-speed travel motor
- Anti-slope turning device
- Waste oil drainage pipeline
- Hydraulic oil regeneration

Electronic Control System

- 12V power battery
- Monitor brightness adjustment
- Maintenance tips
- Safe stop & start function
- Master switch
- Engine start protection
- Multilingual display
- Cab ceiling light
- Automatic diagnosis system
- Automatic idle speed system

Cab

- Ashtray
- Cigarette lighter
- Seat belt
- Shade plate
- Storage compartment
- Emergency hammer
- Air conditioner
- Audio speaker
- Shock absorber
- Flexible aerial
- Radio
- Hydraulic safety locking rod
- Sun proof safety glass
- Cab floor mat
- Pull-up front window
- Dismountable lower windshield
- Sun shade window
- Windshield wiper
- Skylight window
- Cup holder

Swing Platform

- Toolbox
- Large pedal
- Large handrail
- Bottom guard plate

Chassis

- Fixed chassis
- 450mm triple tooth track plate

TECHNICAL SPECIFICATIONS

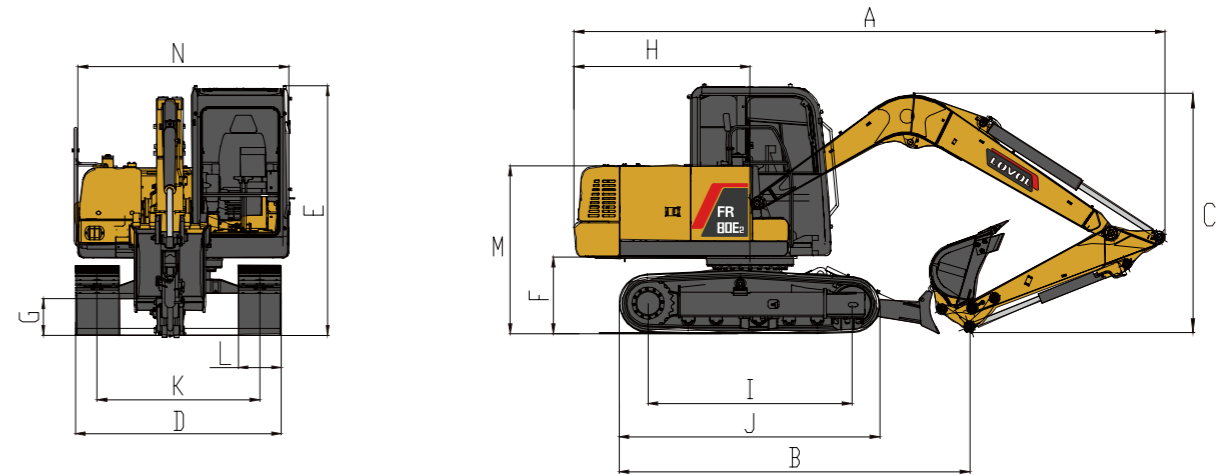

Working Range

| | | |
|-----------------------------|---|--------|
| Max. Digging Height | 1 | 7150mm |
| Max. Dumping Height | 2 | 5030mm |
| Max. Digging Depth | 3 | 4050mm |
| Max. Vertical Digging Depth | 4 | 3670mm |
| Max. Digging Radius | 5 | 6335mm |
| Max. Ground Digging Radius | 6 | 6190mm |
| Min. Turning Radius | 7 | 1770mm |
| Dozer Blade Lifting Height | 8 | 375mm |
| Dozer Blade Falling Height | 9 | 295mm |

Dimensions

| | | |
|------------------------------------|---|--------|
| Shipping Length | A | 6100mm |
| Shipping Ground Length | B | 3665mm |
| Boom Height | C | 2575mm |
| Shipping Width | D | 2275mm |
| Cab Height | E | 2650mm |
| Ground Clearance of Counter Weight | F | 820mm |
| Min. Ground Clearance | G | 378mm |
| Tail Turning Radius | H | 1830mm |
| Length to Center of Rollers | I | 2130mm |
| Track Length | J | 2770mm |
| Track Gauge | K | 1700mm |
| Track Shoe Width | L | 450mm |
| Hood Height | M | 1750mm |
| Rotary Platform Width | N | 2275mm |

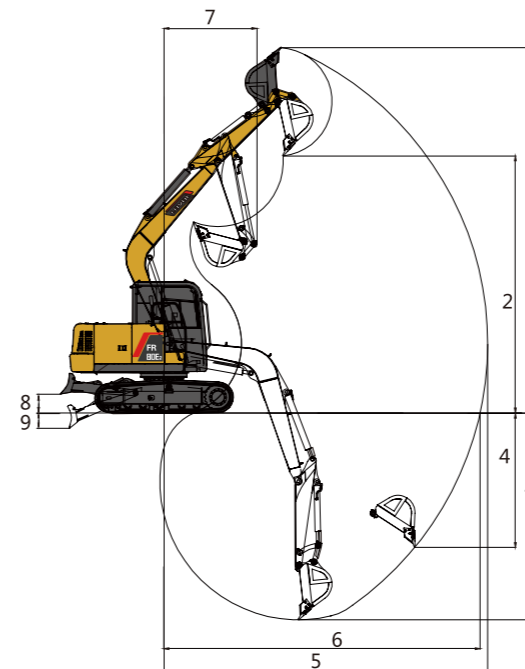

Other Specifications

| | |
|----------------------------------|--------|
| Boom Length | 3708mm |
| Arm Length | 1650mm |
| Track Section Number (each side) | 38 |
| Track Roller Number | 5 |
| Dozer Blade Height | 425mm |