

LOVOL



Engine Model
Rated Power
Operating Weight
Bucket Capacity
Max. Breakout Force

WEICHAI WP10G240E341
178kW
20590kg
4.0m³
180kN

FL966K
WHEEL LOADER

FL966K Wheel Loader Specifications

FL966K Dimensions

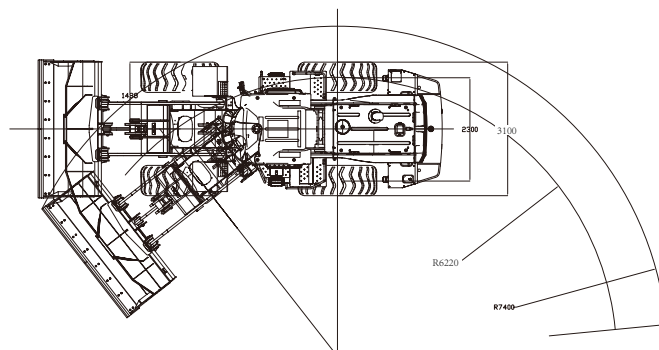
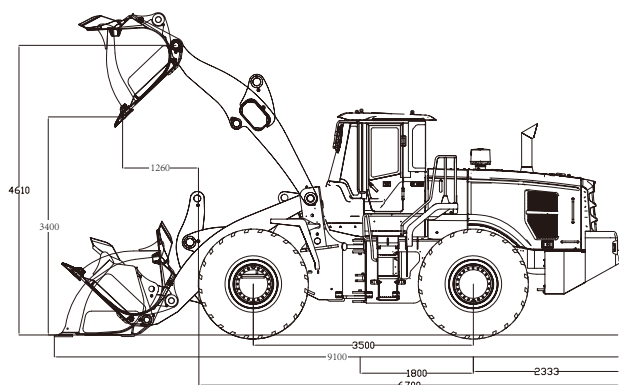

Item	Specifications
Rated Load	6500kg
Max. Traction Force	170kN
Max. Gradeability	29°
Max. Dump Clearance	3400mm
Dump Reach	1260mm
Wheel Tread	2300mm
Wheelbase	3500mm
Overall Dimension (L×W×H)	9100mmx3100mmx3450mm

Engine

Emission Standard	Stage III
Number of Cylinder-Bore/Stroke	6-126*130
Max. Torque	1100N·m
Rated Speed	2200rpm
Displacement	9.726L

Transmission System

Torque Converter	Single stage single phase three element
Modulus of Converter	2.355
Transmission	Electronical control countershaft
Gear Shift	4 forward, 3 reverse
Max. Speed	38.0km/h

Front and Rear Axles

Axles Type	Dry axles
Final Decelerate Type	Planetary reducer, spur cylindrical gear

Tyre

Tyre Size	23.5-25
Ply	24
Front Tyre Pressure	0.47-0.50MPa
Rear Tyre Pressure	0.44-0.47MPa

Steering System

Steering Angle Each Direction	38°
Min. Turning Radius	6220mm

Hydraulic System

Working Pressure	20MPa
Boom Lifting Time	5.7s
Total Cycle Time	10.3s

Brake System

Service Brake	Air over hydraulic caliper disc brake
Park Brake	Air-cut brake

Service Refill Capacity

Fuel Tank	380L
Hydraulic Tank	175L
Engine Oil	20L

LOVOL HEAVY INDUSTRY GROUP CO., LTD.

Address: No. 75, Huanghe East Road, Huangdao District, Qingdao City, Shandong Province, China.

Website: en.wlovol.com

E-mail: lovol_overseas@global.lovol.com

TEL: +86-532-86907190

Facebook: Cons Lovol

As manufacturer, LOVOL has right to constantly upgrade and improve our products without informing to customers. The pictures in literatures are for reference only, the detailed specifications are subject to real products.