

TECHNICAL SPECIFICATIONS



Engine

Engine Model	WEICHAI WP13H
Number of Cylinders	6
Max. Torque/Speed	2050N·m/1200~1400rpm
Displacement	12.9L



Hydraulic system

Max. Main Pump Flow	2x400L/min
Main Safety Valve Pressure	37.3MPa



Main Performance

Bucket Digging Force	363kN
Arm Digging Force	250kN
Max. Traction Force	380kN
Max. Walking Speed	5.1km/h
Min. Walking Speed	3.2km/h
Rotary Speed	7.5r/min
Gradeability	35°
Ground Pressure	99kPa



Oil Capacity

Fuel Tank	780L
Hydraulic Tank	350L
Engine Oil	40-52L



LOVOL HEAVY INDUSTRY GROUP CO., LTD.

Address: No. 75, Huanghe East Road, Huangdao District, Qingdao City, Shandong Province, China.

Website: en.lovol.com

Alibaba: lovolconstruction.en.alibaba.com

Facebook: Cons Lovol

E-mail: lovol_overseas@global.lovol.com

TEL: +86-532-86907190

As manufacturer, LOVOL has right to constantly upgrade and improve our products without informing to customers. The pictures in literatures are for reference only, the detailed specifications are subject to real products.



Rated Power

316kW/1900rpm

Operating Weight

58000kg

Bucket Capacity

3.6m³

FR600F-HD

EXCAVATOR



RELIABILITY

Advanced Technology

First-user of function-relief cushion valve system in industry, machine's respond could keep the same speed even in the extreme cold weather. On the premise of keeping the optimal impact pressure, the starting or switching of working device without any postpone, that makes smooth, efficient and energy-saving operation of machine and reaches to leading level of industry.

Powerful Engine

The new generation of CUMMINS QSM11 engine originally imported from America which is specially designed for mining applications. Its exclusive PT fuel control and injection technology delivers higher precise and full efficient traits compared to traditional electric controlled high-pressure common rail technology.

Electric Control Positive Flow System

During the design stage, LOVOL has utilized the latest technologies to develop an integrated hydraulic system. The positive flow control system adjusts the displacement of pump and the motion of valve spool simultaneously, delivering optimal operating experience for the operator with smooth and responsive control.

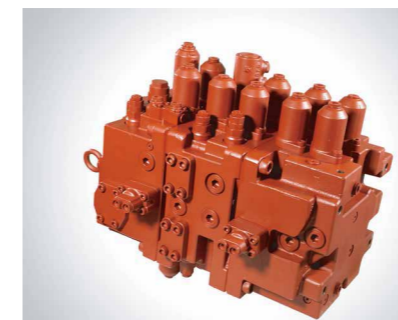

PRODUCTIVITY

Superb Match

Each component in powertrain system, such as engine, gear, rotary motor, working pumps and hydraulic cylinder are specially customized to achieve perfect match with one another, the whole system features are more reliable.

Great Digging Force

On the premise of ensuring static digging force, LOVOL dedicate to research of dynamic digging force. The system will automatically detect the pressure when face big frustration during digging, and automatically adjust output pressure to keep the powerful force in digging process.

Larger Bucket

Equipped with larger bucket which is specially designed to achieve maximum productivity and durability. The unique shape design improves the bucket's stability when doing loading job. Applying with latest technology and optimal hydraulic system, it has good performance on fuel consumption.

ROBUSTNESS



Rigorous Test and Experiment

Machine test: LOVOL CL-6 machine testing yard covers more than 200,000 square meters, it can simulate various applications like earthmoving, aggregate, sand, quarry and forth. The test including strengthen vibration, noise, working efficiency, oil consumption, travel and climbing tests, etc. Every new model should go through more than 2,000 working hours strengthen combination test here.

Robust Chassis

Reinforcement of Track Roller, Carrier Roller, Idler, Drive Roller and Track makes brace capacity increase dramatically which can also working in the temperature of -45 C. The crawl tracks are made of high-strength anti-wear steel, with great grip on ground.

Reinforced Working Device

Adopts high-strength rock bucket teeth which is special suitable for the tough applications, the boom and arm are reinforced to prolong the service life. Self-lubrication shaft sleeve is used to make every linkage works smoothly with high durability.

COMFORT

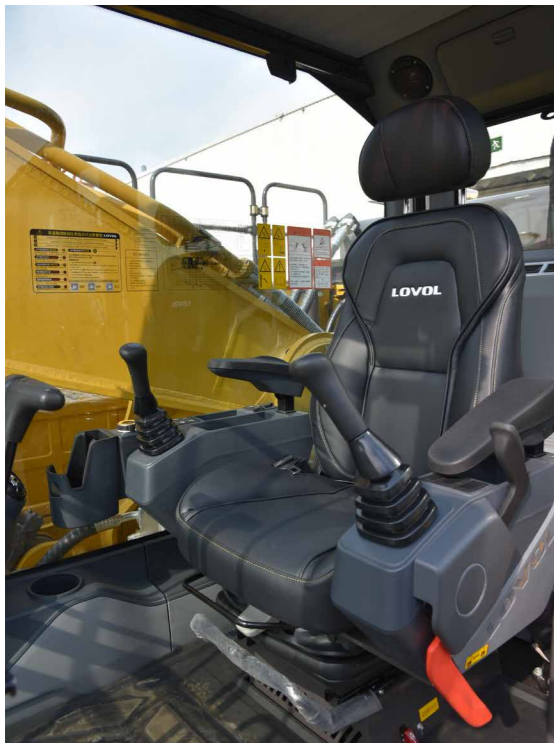

Large Spacious Cab

Equipped with spacious cab which provides operator large space to operate machine. The premium suspension seat with armrests is very comfortable and it can reduce the working fatigue dramatically. Front windshield can be partially or fully retracted to the cab roof. Rearview camera is optional to get better rear vision in order to improve operation safety in jobsite.

Ergonomic Design

The proportional joystick delivers sensitivity, accuracy and smoothness during operation. This joystick is specially designed to meet different operating conditions. Intelligent control system is standard which could control diverse attachments such as bucket, hammer, scarifier and hydraulic scissors.

Low Noise and Low Vibration

In order to reduce work fatigue and improve productivity, the noise inside of cab has been controlled to the lowest level. The cab is attached to the frame with buffer that dampens vibrations and sound levels to enhance operator comfort.

INCREASE YOUR PRODUCTIVITY AND PROFIT WITH LOVOL ATTACHMENTS

You can easily expand the performance of your machine by utilizing any of the variety of LOVOL Attachments. Each LOVOL Attachments is designed to fit the weight and horsepower of LOVOL Excavator for improved performance, safety, and stability.

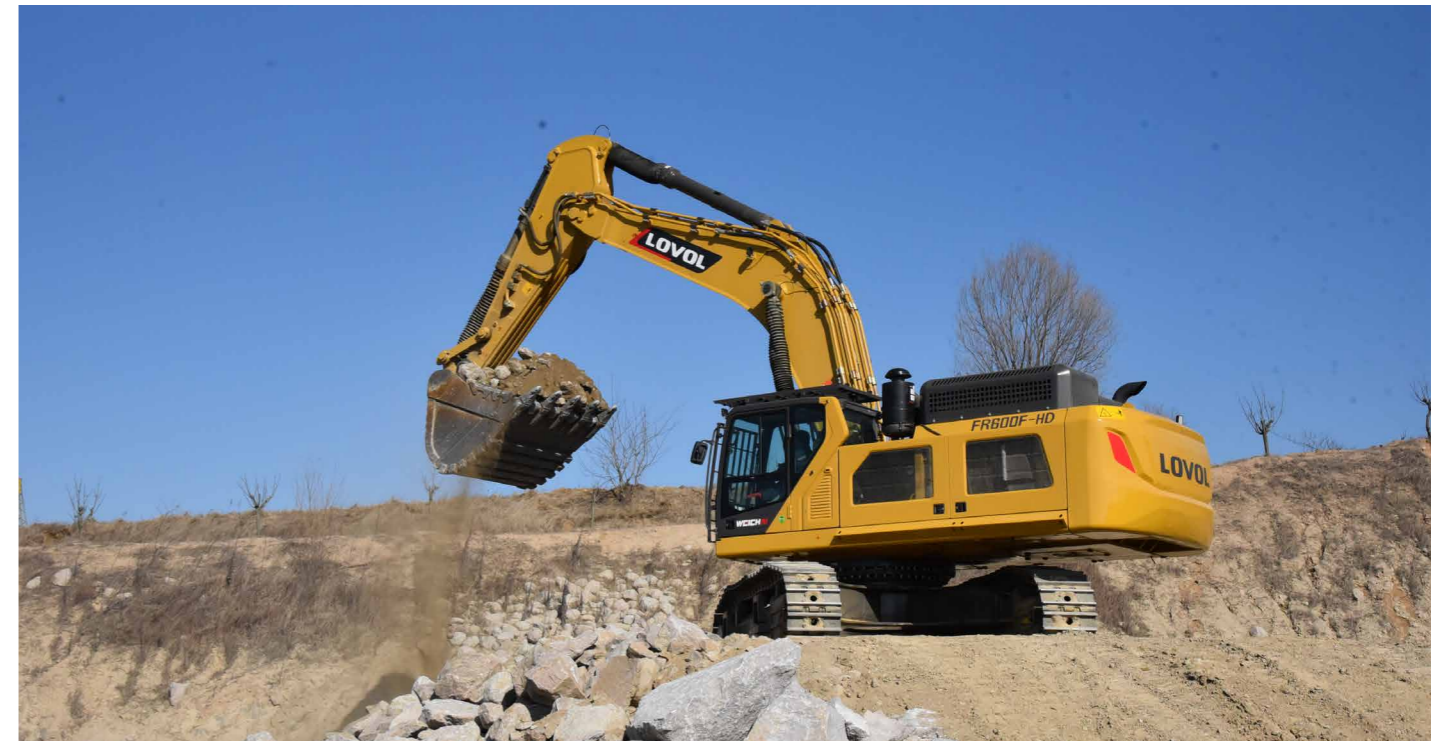

Hydraulic Hammer



Scarifier



Standard Bucket



STANDARD CONFIGURATION

Engine

- Turbocharged, 6-cylinders, water-cooling, direct injection
- Radiator with protective fence
- Oil bath type cleaner
- Air intake heater
- Fan guard
- Double filters, dry air filter
- Engine oil pan with oil drain valve
- Automatic idle speed system
- Three-stage fuel filter
- 75A/24V alternator

Cab

- Ashtray
- Cigarette lighter
- Seat belt
- Shade plate
- Storage compartment
- Emergency hammer
- Air conditioner
- Audio speaker
- Shock absorber
- Flexible aerial
- Radio
- Hydraulic safety locking rod
- Sun proof safety glass
- Cab floor mat
- Pull-up front window
- Dismountable lower windshield
- Sun shade window
- Windshield wiper
- Skylight window
- Suspended seat
- Big storage area

Chassis

- Fixed chassis
- 600mm double tooth track plate

Hydraulic System

- Automatic hydraulic system (flow confluence system)
- Multistage filtration system
- Anti-sway valve
- Boom and stick locking valve
- Cylinder buffer device
- Anti-slope turning device
- Waste oil drainage pipeline
- Pilot buffer valve (rotary, stick, boom)
- Dual-speed travel motor
- Hydraulic hammer pipeline

Electronic Control System

- 24V power battery
- Monitor brightness adjustment
- Maintenance tips
- Safe stop & start function
- Master switch
- Engine start protection
- Multilingual display
- Cab ceiling light
- Diagnostic interface
- Emergency stop switch
- Automatic diagnosis system
- Automatic idle speed system
- One-touch pressure enhancement
- Anti-theft system

Swing Platform

- Toolbox
- Large pedal
- Large handrail
- Bottom guard plate
- Anti-crash beams
- Anti-skid plates
- Passage with handrails

TECHNICAL SPECIFICATIONS

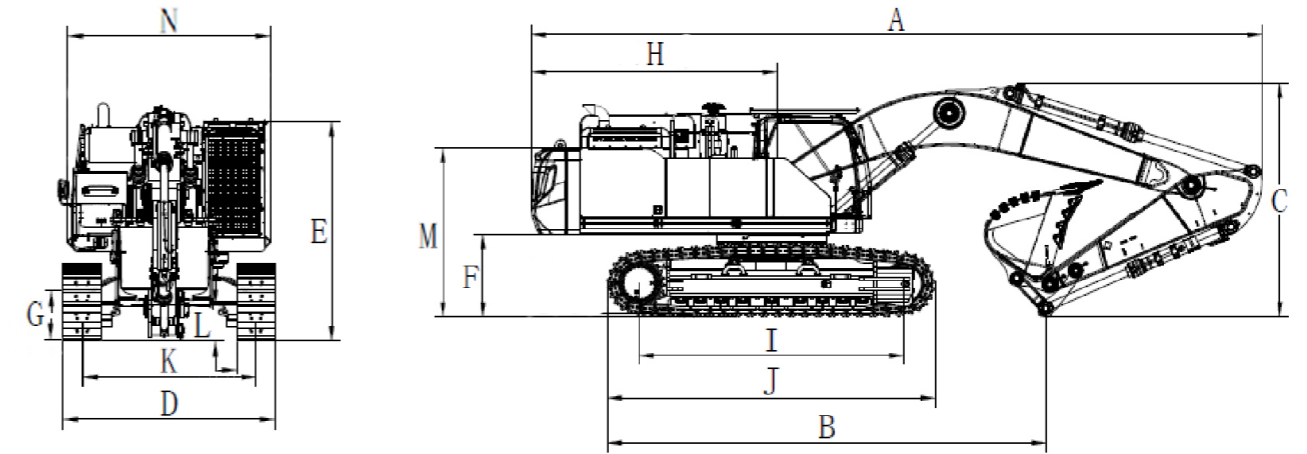

Working Range

Max. Digging Height	1	10085mm
Max. Dumping Height	2	6642mm
Max. Digging Depth	3	7052mm
Max. Vertical Digging Depth	4	3489mm
Max. Digging Radius	5	11169mm
Max. Ground Digging Radius	6	10920mm
Min. Turning Radius	7	4983mm

Dimensions

Shipping Length	A	11800mm
Shipping Ground Length	B	4600mm
Boom Height	C	3988mm
Shipping Width	D	3680mm
Cab Height	E	3544mm
Ground Clearance of Counter Weight	F	1472mm
Min. Ground Clearance	G	602.5mm
Tail Turning Radius	H	4040mm
Wheel Tread	I	4600mm
Track Length	J	5705mm
Track Gauge	K	2890mm
Track Shoe Width	L	600mm
Hood Height	M	2880mm
Rotary Platform Width	N	3200mm

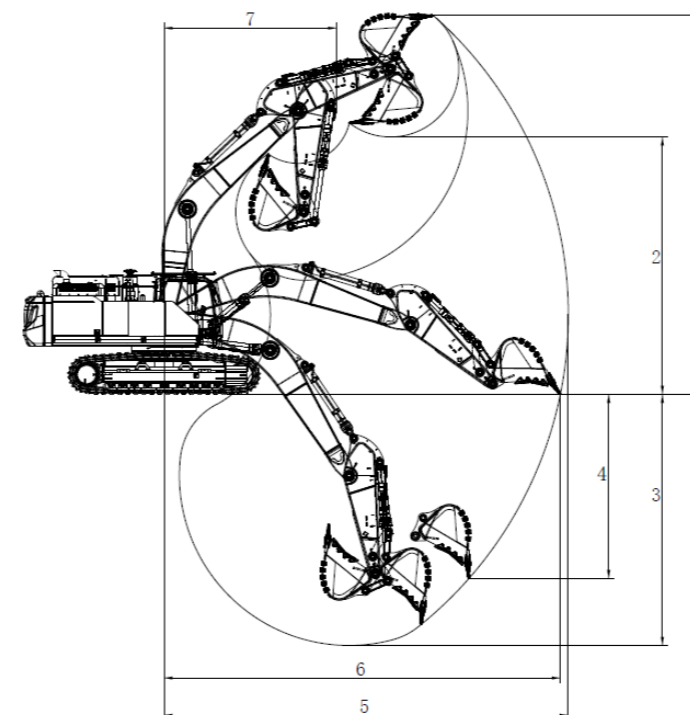

Other Specifications

Boom Length	6500mm
Arm Length	2900mm
Track Section Number (each side)	52
Track Roller Number	9